

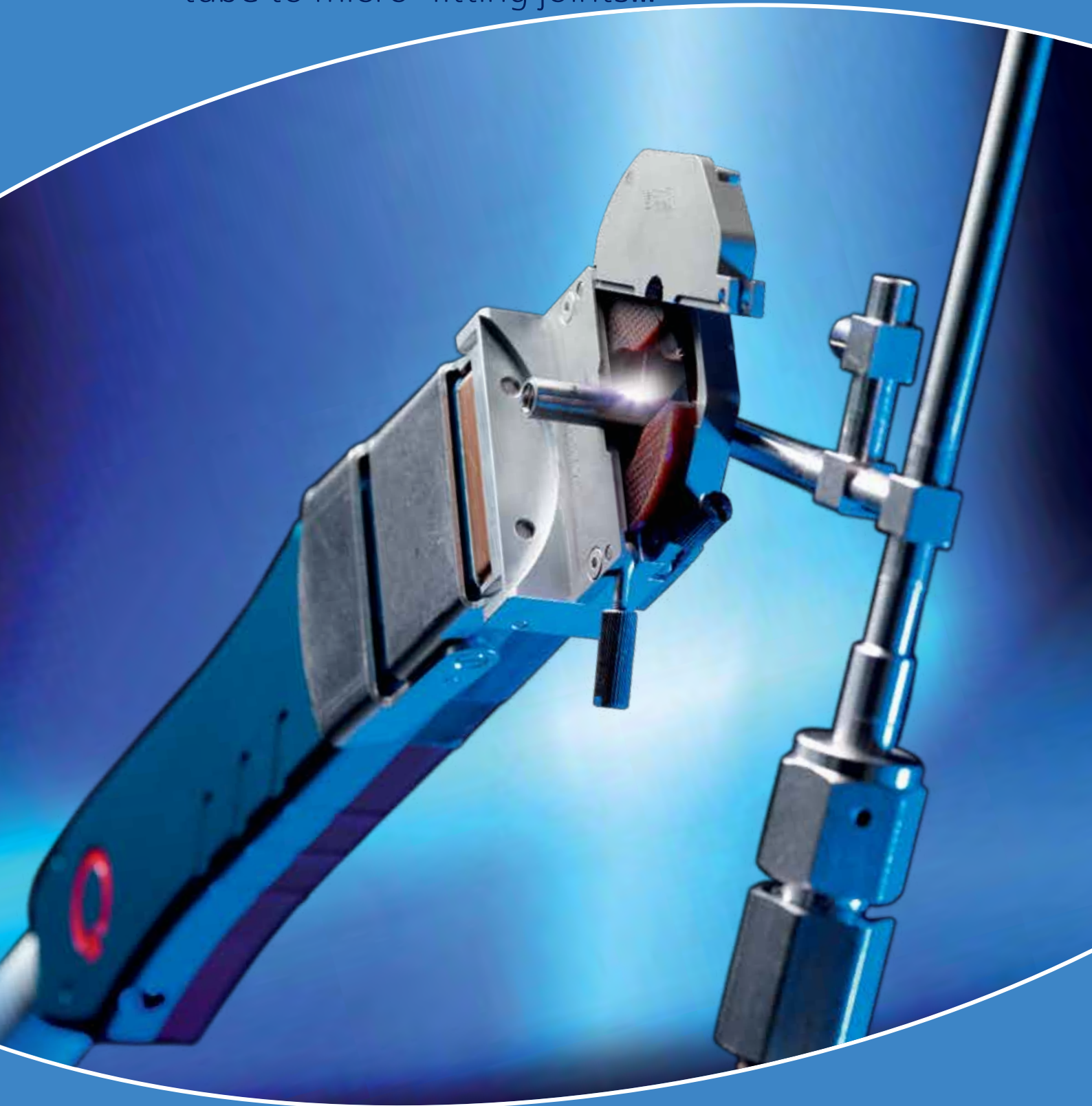

TIG - Without Filler Wire

Closed chamber welding head

for welding of tube to tube joints,
tube to micro-fitting joints...





Closed chamber welding head

for welding of tube to tube joints,
tube to micro-fitting joints...

A range of modular standard welding heads, perfectly adaptable to your needs

Advantages

- ▶ Oxidation-free welds
- ▶ Reduced radial and axial dimensions
- ▶ Three modules covering a large range of diameters
- ▶ Clamping system adaptable to the work piece design for all types of applications

Resulting from 50 years' experience
in mastering welding technologies



A modular concept:

- ▶ unique drive handle
- ▶ three electrode gear modules 1/4"; 1/2"; 1 1/3"
- ▶ removable clamping cassettes

Narrow welding head profile for use in areas with constrained radial and axial clearance

Removable Titanium clamping cassettes (UHP 250-2 and 500-2) or flexible Tube Clamp Inserts – TCI's™ (UHP 1500-2). Comply with standard tube O.D. sizes and tolerances, for hygienic and high purity requirements

High purity gas circuit to avoid particle emission and oxidation

Return-to-home feature: the electrode gear automatically returns to its loading position

Non symmetrical design for welding of fittings with short stick-out

Closed loop regulation to ensure precise, constant or pulsed welding speed

LED: home position

Encoder for position based control of the welding program

General characteristics



Removable Titanium clamping cassette for UHP 250-2



Removable Titanium clamping cassette for UHP 500-2



Removable clamping system and titanium TCI's™ for UHP 1500-2



Removable Fixture-Blocks for all types of micro-fittings, providing perfect tube end centring, alignment and great clamping force (UHP 500-2)

Associated Power Sources



▶ PS 164-2

160 A, "all inclusive", portable, single-phase power supply



▶ P4

170 A, "modular", portable, programming by PC or touch screen, single-phase power supply

Type	Tube O.D. in mm / inches	
UHP 250-2	1.60 – 6.35 mm	1/16" – 1/4"
UHP 500-2	3.00 – 12.70 mm	1/8" – 1/2"
UHP 1500-2	6.00 – 33.70 mm	1/4" – 1 1/3"

Type	Dimensions in mm / inches								
	A	B	C	D	E	F	G	H	J
UHP 250-2	27.8 (1.09")	11.9 (0.47")	5.6 (0.22")	31.6 (1.24")	16.5 (0.65")	22.3 (0.88")	257 (10.12")	23 (0.9")	44.5 (1.75")
UHP 500-2	25.4 (1")	12 (0.47")	5.7 (0.22")	51.3 (2.02")	25.7 (1.01")	23 (0.91")	261 (10.28")	23 (0.9")	44.5 (1.75")
UHP 1500-2	35 (1.38")	29 (1.14")	14.75 (0.58")	92 (3.62")	46 (1.81")	42.5 (1.67")	295 (11.61")	23 (0.9")	44.5 (1.75")

Cable length: 5.5 m

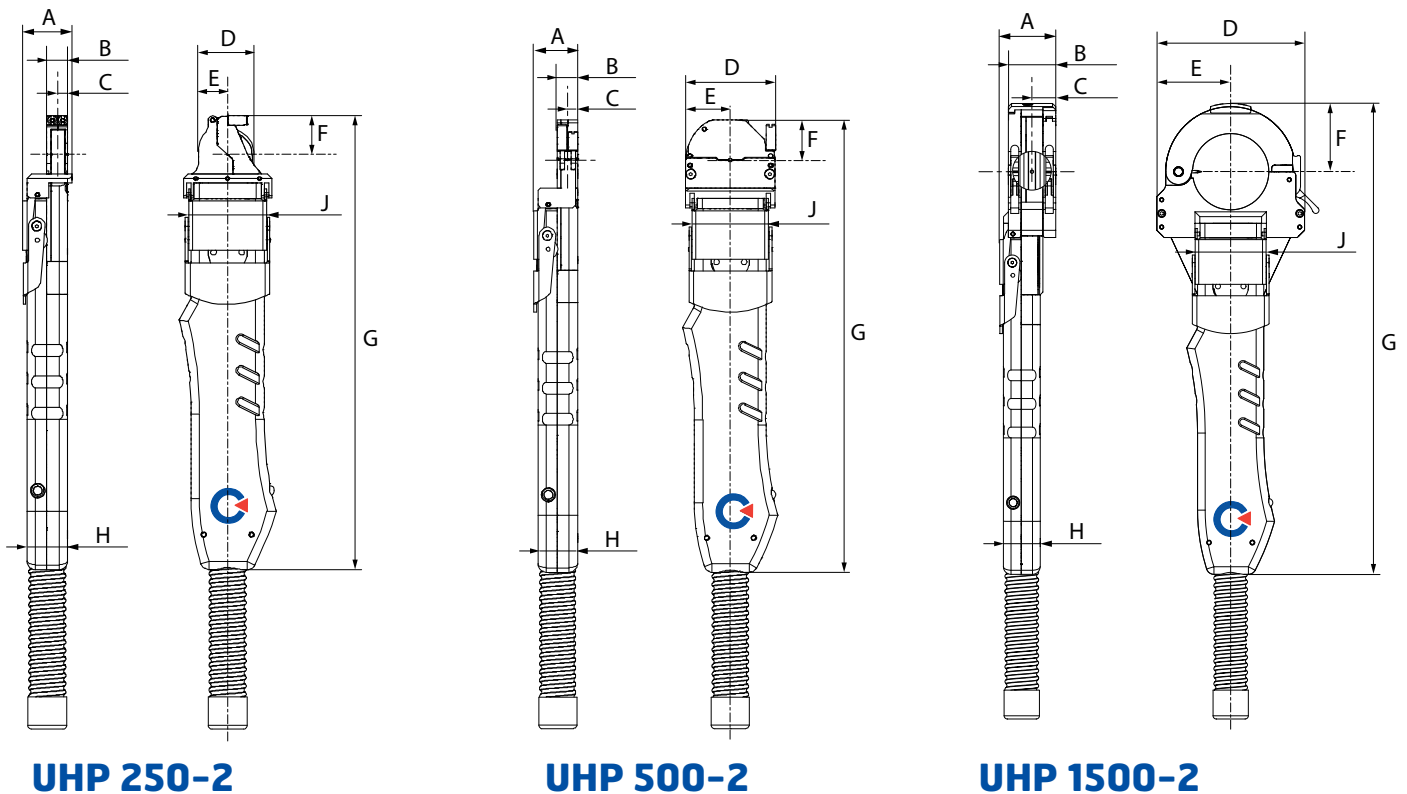

UHP 250-2

UHP 500-2

UHP 1500-2



Options and accessories

- Removable Titanium clamping cassettes and Tube Clamp Inserts – TCI's™ for all tube and pipe O.D.s available both in metric and imperial sizes
- Removable Fixture-Blocks for all types of micro-fittings, providing perfect tube end centring, alignment and great clamping force (UHP 500-2)
- Interchangeable electrode gear modules 1/4" ; 1/2" ; 1 1/3" for optimised use of axial and radial clearance around the welding joint
- Extension cable (15 m)
- Dual welding head switch box
- Compact shipping case for transport and storage
- Tungsten electrodes, pre-sharpened and pre-cut
- Tool-kit for daily operations

 Adapted for all your applications!

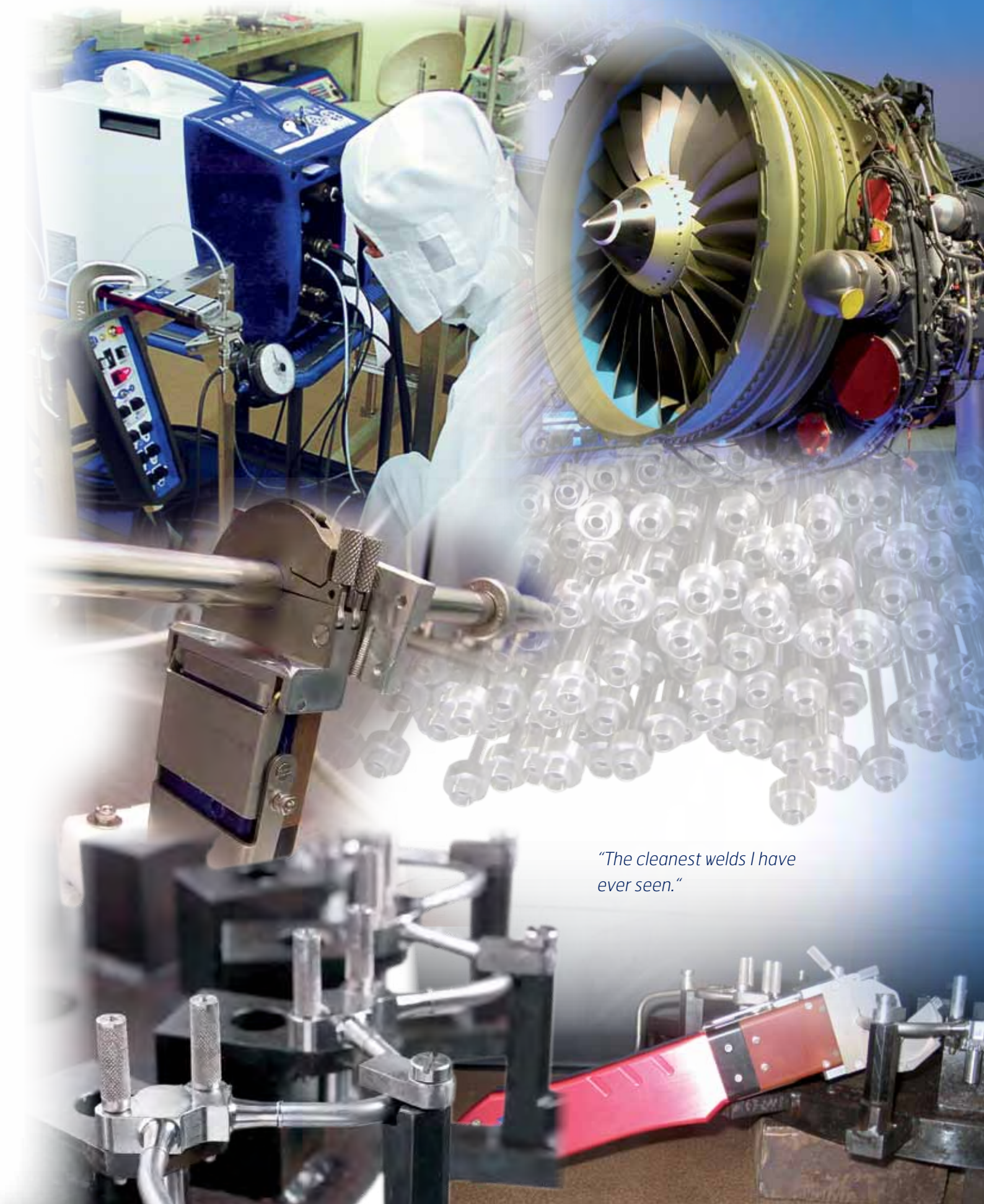

"The cleanest welds I have ever seen."