

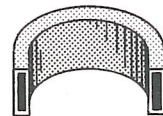

TOOLS FOR BENDING, INC.

SQUARE AND RECTANGULAR TOOLS

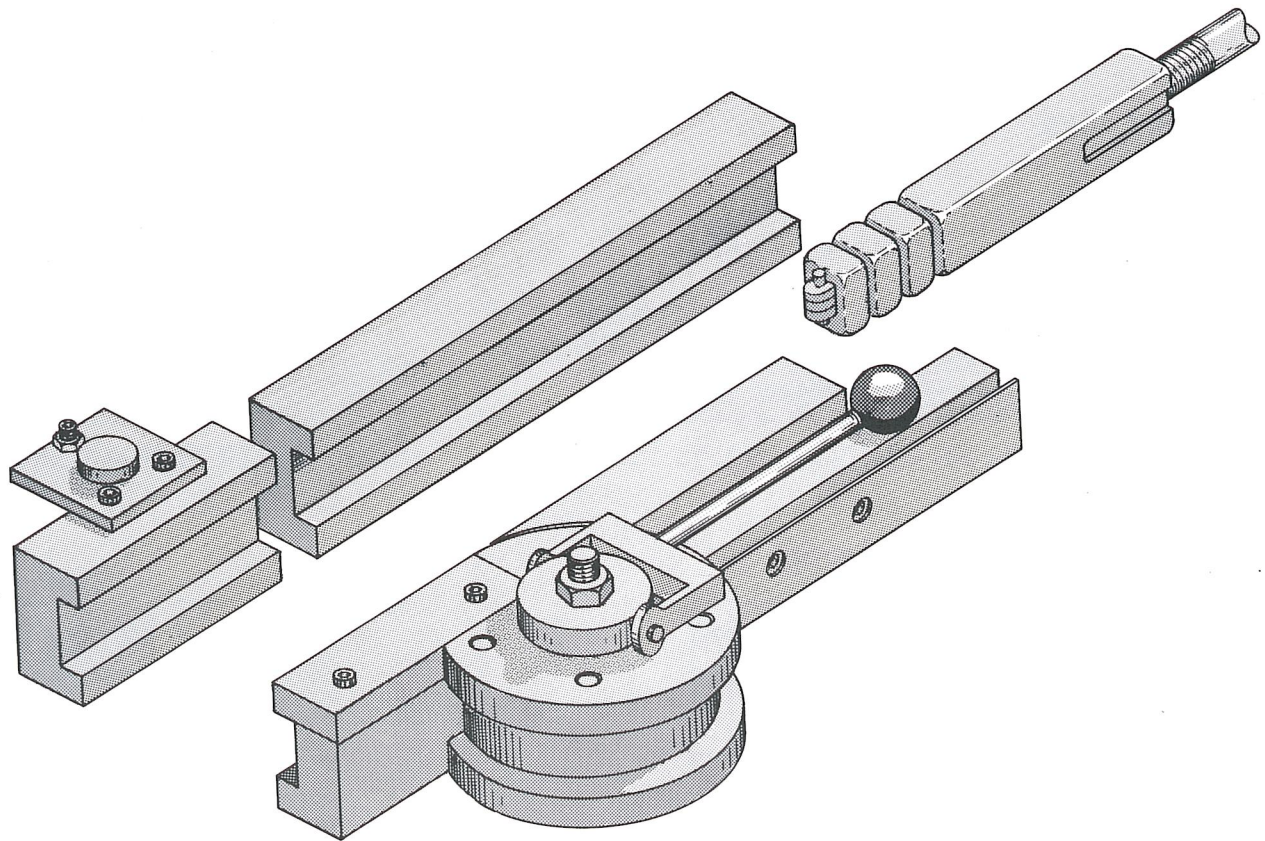

"E" PLANE OF BEND

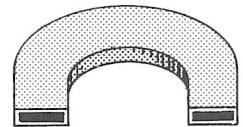

"H" PLANE OF BEND

**NOTE**

Bending square, rectangular, or extruded shapes are much more difficult than round tubing. Multiple ball mandrels and wiper dies are more frequently used. To help determine what tooling is required, refer to mandrel selection guide (page 5). We suggest calculating application for a round tube and adding 20 to O.D. to wall factor.

Bend dies are split horizontally to permit the top half to be raised and lowered. If a hydraulic split die actuator is not available, a manually operated cam lock can be furnished by T. F. B., Inc.

**SPECIFY**

1. Tube Dimensions and C. L. R.
2. Make and Size of Bender
3. Degree of Bend
4. "E" or "H" Plane
5. Corner Radius of Tube
6. Weld Flash
7. Special Requirements