

SUPERBOILER T5

Range ØI 49-203mm (1,92"-7,99")

La **Superboiler T5** è una macchina indispensabile per chi deve lavorare un ampio range di tubi anche in condizioni gravose. La potenza della macchina permette di ottenere smussi accurati anche sugli spessori più importanti.

The **Superboiler T5** is the indispensable pipe beveler for those who have a wide range of pipe diameters and work in heavy working conditions. The power of the unit delivers accurate bevels even on heavy wall.

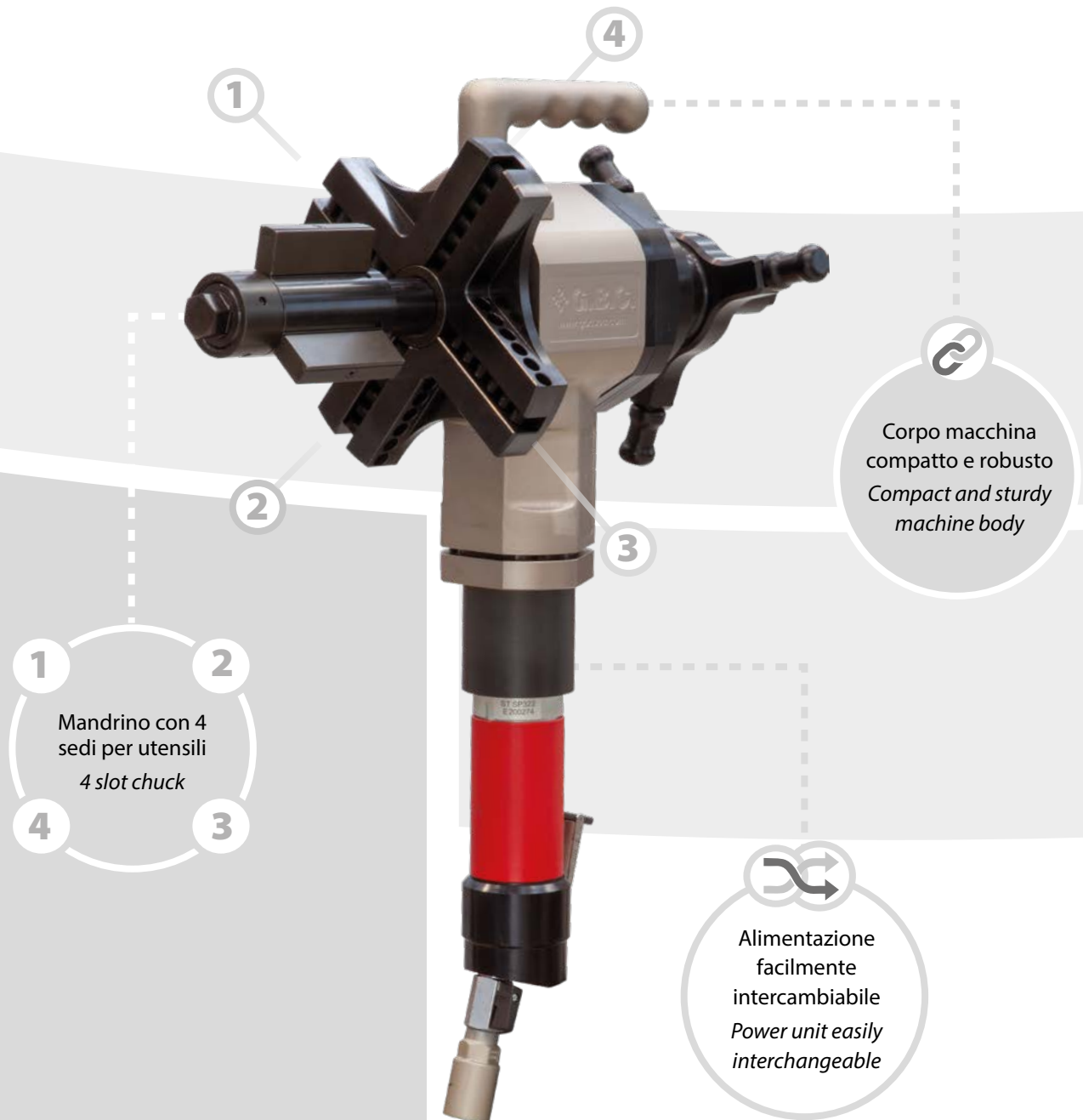

1 2
Mandrino con 4
sedi per utensili
4 slot chuck
4 3

Corpo macchina
compatto e robusto
Compact and sturdy
machine body

Alimentazione
facilmente
intercambiabile
Power unit easily
interchangeable

- Campo di lavoro: 49-203mm DI (1,92"-7,99");
- Materiali: acciai al carbonio, inox, duplex, inconel, altri;
- Alimentazione: pneumatica / elettrica / idraulica.

- Working range: 49-203mm ID (1,92"-7,99");
- Materials: carbon steel, stainless steel, duplex, inconel, others;
- Drive: pneumatic / electric / hydraulic.

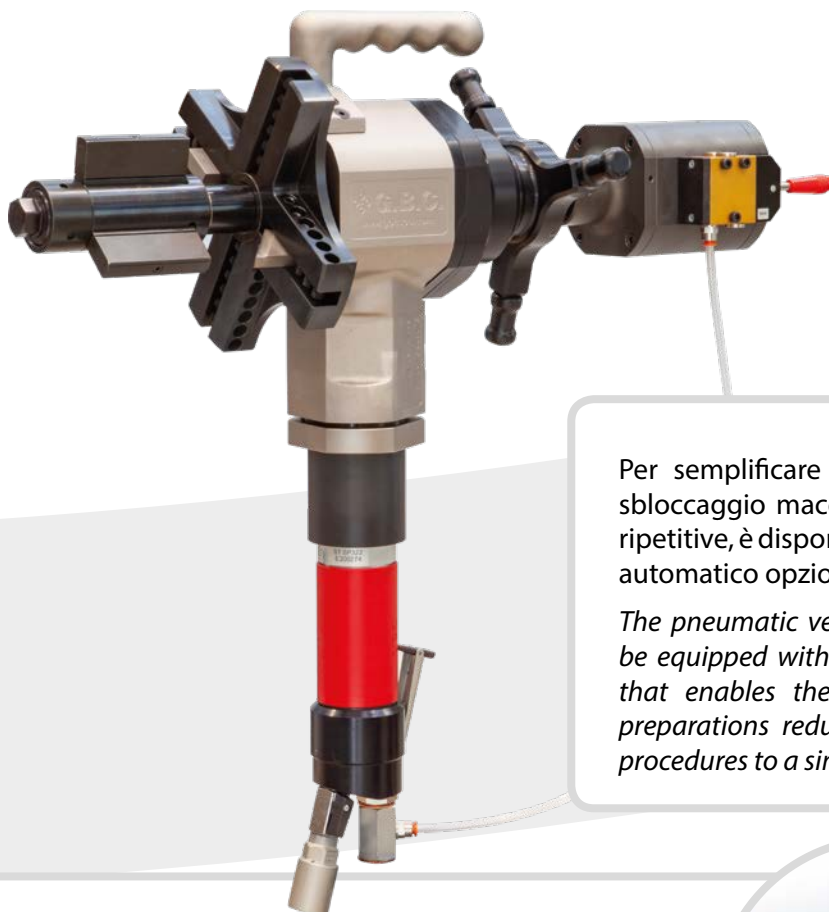
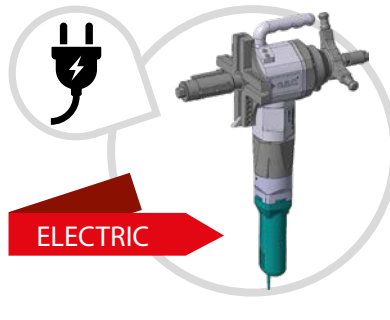
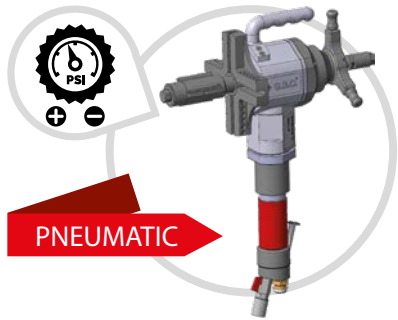

Per semplificare le operazioni di bloccaggio e sbloccaggio macchina durante le operazioni più ripetitive, è disponibile un bloccaggio pneumatico automatico opzionale.

*The pneumatic version of the **Superboiler T5** can be equipped with an optional auto-locking device that enables the operator to execute repetitive preparations reducing the locking and unlocking procedures to a simple flick of a lever.*

La macchina può essere dotata di alberi opzionali per lavorazione su curve con diametro da 46 a 207mm DI.
The machine can be equipped with optional elbow locking shafts for elbows and tees from 46 to 207mm ID.



SUPERBOILER T5

Range ØI 49-203mm (1,92"-7,99")

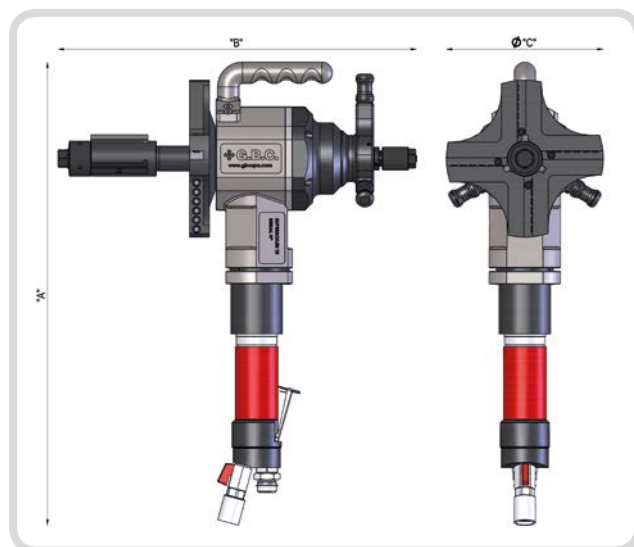

ALBERI RIDOTTI - REDUCED SHAFTS

Albero Shaft	Capacità Bloccaggio Interno Locking Range ID
# K20454	98-207mm
# K20498	46-103mm

DIMENSIONI E INGOMBRI - DIMENSIONS AND SIZES

Alimentazione/Drive	Dim. A (mm)	Dim. B (mm)	Dim. C (mm)
Pneumatic	650	502	220
Pneumatic + autolocking	670	660	220
Electric	645	502	220

DATI TECNICI - TECHNICAL FEATURES

		SUPERBOILER T5 Pneumatic	SUPERBOILER T5 Electric
Capacità di bloccaggio (Ø I) Locking range (Ø ID)	mm pollici - inches	49-203 1,92-7,99	49-203 1,92-7,99
Velocità a vuoto Idle speed	gg/min (rpm)	44	28
Coppia massima mandrino Max. chuck torque	Nm	565 (6 bar) 802 (8 bar)	467
Avanzamento assiale Stroke	mm pollici - inches	40 1,57	40 1,57
Potenza motore pneumatico Pneumatic motor power	Hp W	1,74 1300	-
Consumo aria Air consumption	NI/min cfm	1300 45,9	-
Pressione aria Air pressure	bar psi	6 ÷ 8 87 ÷ 116	-
Connessione attacco aria Air hose connection	pollici - inches	3/4"	-
Potenza motore elettrico Electric motor power	W	-	1900
Tensione Tension	Volt	-	110/220
Frequenza Frequency	Hz	-	50/60
Emissione acustica max Max. acoustic emission	Db	75	75
Peso macchina Machine weight	Kg	24	25